

DESCRIPTION

Sanland's SL18 is a broadband GaAs MMIC low noise amplifier ideally suited for 0.4-8GHz microwave radios where small size and low power consumption are critical design requirements. The broadband device delivers 21 dB of gain with a corresponding output 1 dB compression point of +17 dBm and a noise figure of 1.8 dB. The SL18 Low Noise Amplifier MMIC is a 50 ohm matched design eliminating the need for external RF port matching. The SL18 also offers full passivation for increased reliability and moisture protection

Major Applications

- Electronic Warfare (EW)
- Analog optical links
- S Band Radar
- C Band Radar
- Space
- Satellite Communications (Satcom)
- Phased Arrays

KEY FEATURES

- Single 3.3V Supply
- High gain broadband performance
- Low current consumption 75mA@3.3V
- 1.8 dB noise figure at 2000MHz
- Miniature DFN (8-pin, 2 x 2 mm) package



8 pin 2x2 mm DFN Package



Pin Assignment

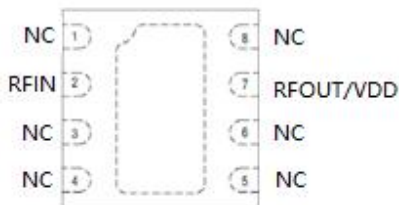

Pin Details

Pin Number	Name	Description
1,3,4,5,6,8	NC	No connection. May be connected to ground with no change in performance.
2	RF in	RF input. DC blocking capacitor required.
7	RFOUT/VDD	RF output. Apply VDD through RF choke inductor. DC blocking capacitor required.

Absolute Maximum Ratings

Parameter	Rating	Unit
DC Power Supply	+4	V
Quiescent supply current	100	mA
RF Input Power	30	dBm
Operating Temperature	-40 to +105	°C
Storage Temperature	-65 to +150	°C
Operation beyond any one of these limits may cause permanent damage.		

Thermal Data

Parameter	Specification			Units	Notes
	Min	Typ.	Max		
Thermal resistance		45		°C/W	
Channel temperature @ +85 °C reference (package heat slug)		101		°C	VDD = 3.3 V, IDQ = 72mA, no RF applied , dissipated power=0.2376W
Test Conditions : VDD = 3.3 V, TA = +25 °C, PIN = -25 dBm , Characteristic Impedance [ZO] = 50 Ω, Unless Otherwise Noted.					

Important Note:

The information provided in this datasheet is deemed to be accurate and reliable only at present time. Sanland Technology Corp. reserves the right to make any changes to the specifications in this datasheet without prior notice.



Caution: ESD Sensitive
Appropriate precaution in handling, packaging
And testing devices must be observed.

400 to 8500 MHz Optimized Tuning

Parameter	Specification			Units	Notes
	Min	Typ.	Max		
RF Specifications					
NF		1.5		dB	1 GHz, includes Evaluation Board loss
S21		21.6		dB	1 GHz
S11		23.3		dB	1 GHz
S22		12.1		dB	1 GHz
S12		25.3		dB	1 GHz
OIP3		+34.1		dBm	1 GHz, $\Delta f = 1$ MHz, PIN = -25 dBm/tone
OP1dB		+18.1		dBm	1 GHz
DC Specifications					
VDD		3.3		V	
IDQ		72		mA	Set with external resistor
Test Conditions : VDD = 3.3 V, TA = +25 °C, PIN = -25 dBm, Characteristic Impedance [ZO] = 50 Ω , Unless Otherwise Noted					

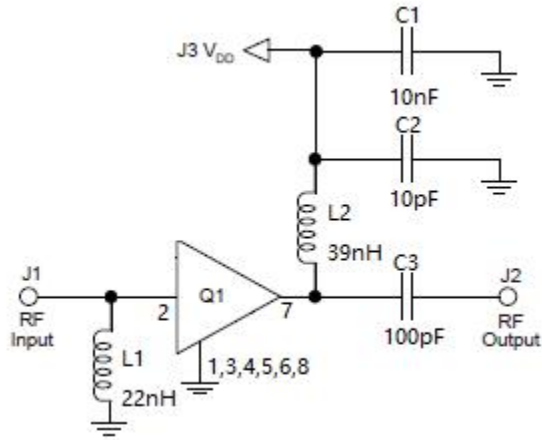

Component	Description	Value	Size	Manufacturer	Part Number
L1	Inductor	22nH	0402	Coilcraft	
L2	Inductor	39nH	0402	Coilcraft	
C1	Capacitor	10nF	0402	Murata	
C2	Capacitor	10pF	0402	Murata	
C3	Capacitor	100pF	0402	Murata	

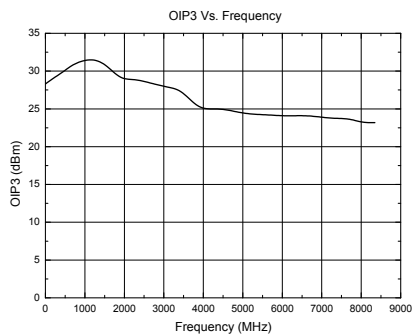
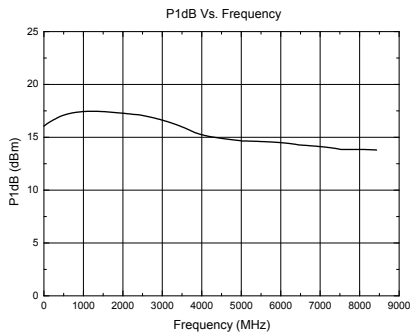
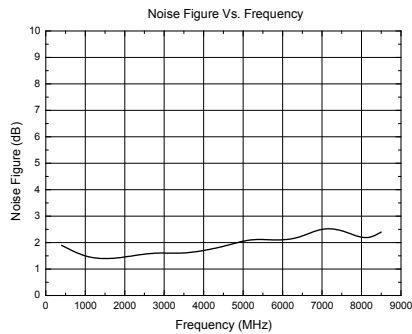
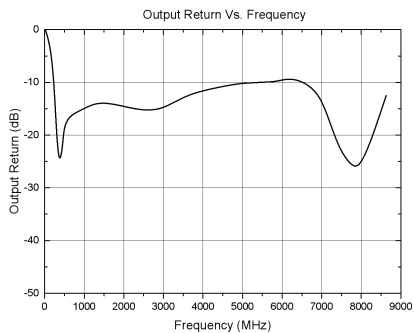
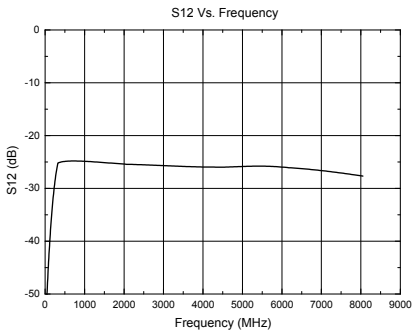
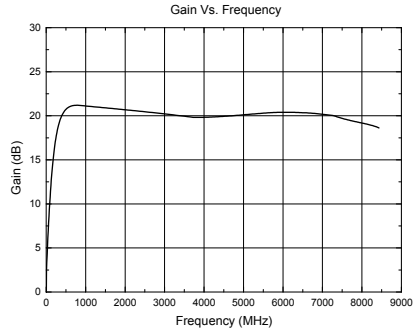
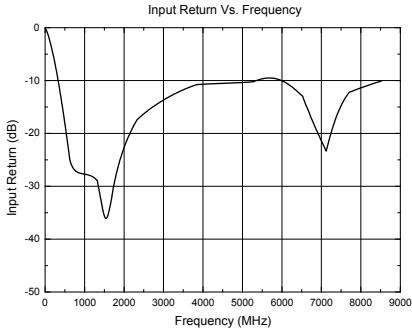

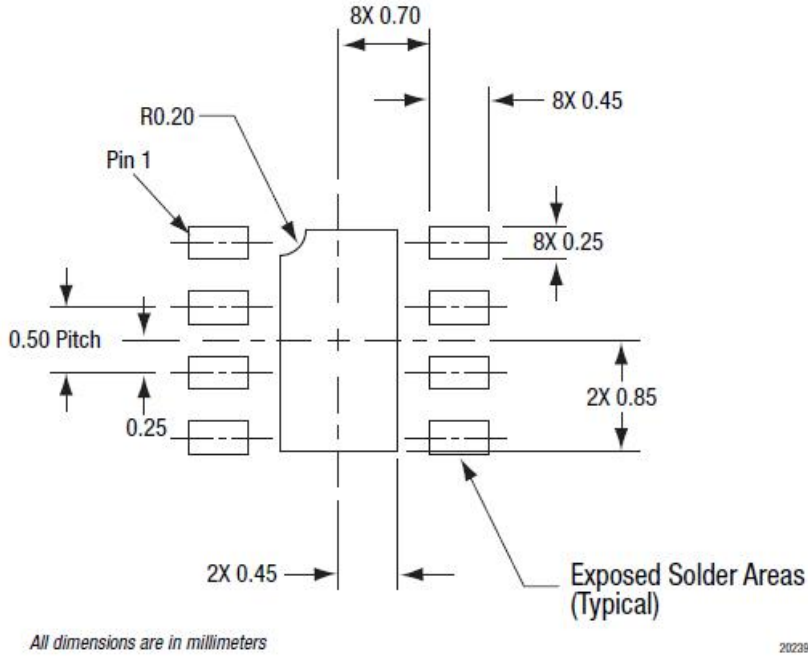

PCB Layout Footprint (Top View)

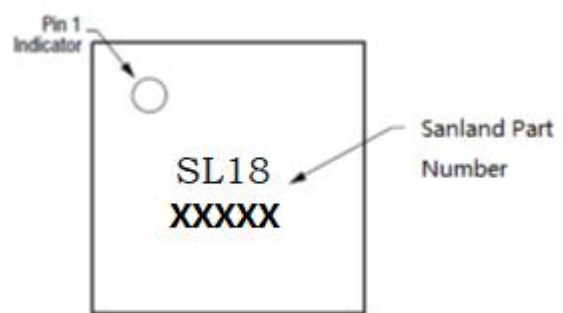

Typical Part Markings (Top View)

SL18

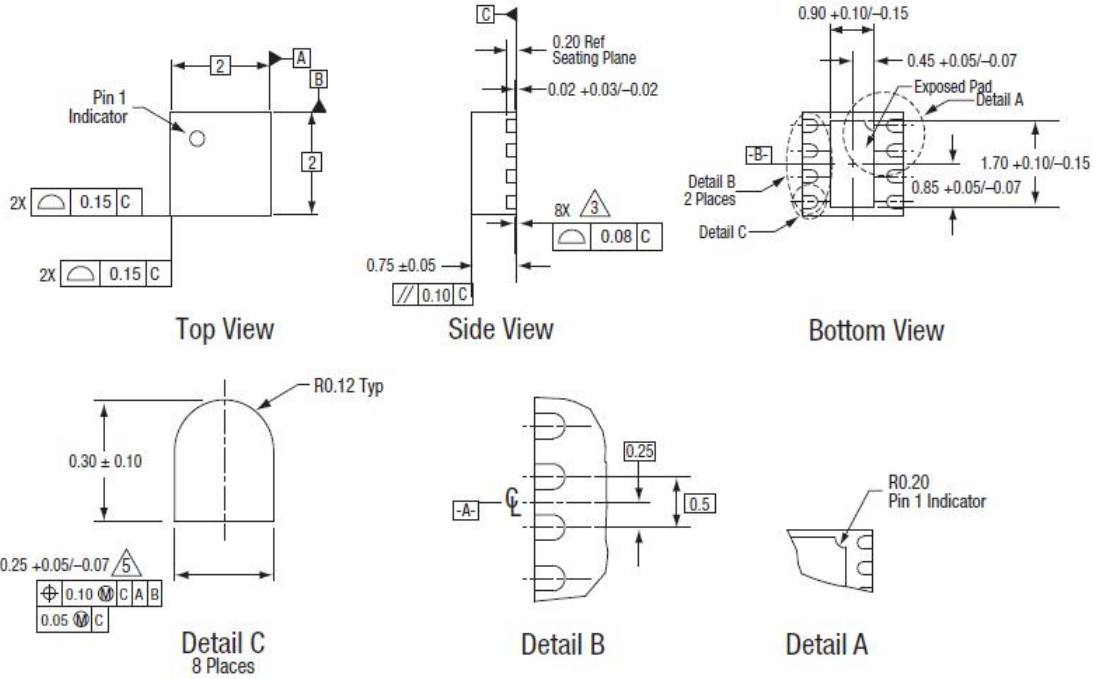

Notes:

1. All measurements are in millimeters.
2. Dimensions and tolerances according to ASME Y14.5M-1994.
3. Coplanarity applies to the exposed heat sink ground pad as well as the terminals.
4. Plating requirement per source control drawing (SCD) 2504.
5. Dimension applies to metallized terminal and is measured between 0.15 mm and 0.30 mm from terminal tip.

202390-027

Package Dimensions

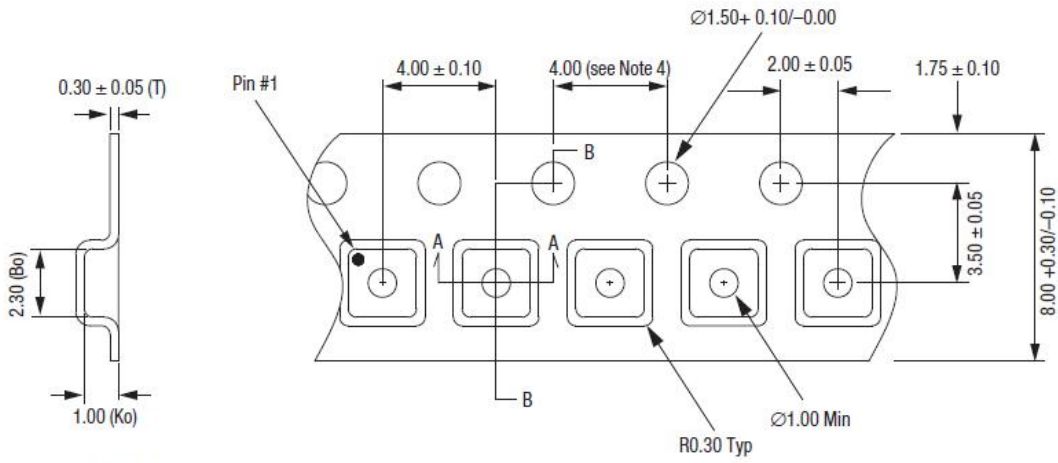

Detail B

Notes:

1. Carrier tape: black conductive polystyrene.
2. Cover tape material: transparent conductive HSA.
3. Cover tape size: 5.40 mm width.
4. Ten sprocket hole pitch cumulative tolerance = ± 0.20 mm.
5. ESD surface resistivity is $\leq 1 \times 10^8$ Ohms/square per EIA, JEDEC tape and reel specification.
6. Ao and Bo measurement point to be 0.30 mm from bottom pocket.
7. All measurements are in millimeters.

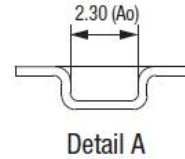

Detail A

202390-028

Tape and Reel Dimensions